

# Mist Fighter Series Coolant Mist Collectors

AER Control Systems Mist Fighter Series Coolant Mist Collectors are designed to provide efficient, cost effective control of coolant mist contaminants generated from a variety of manufacturing and process applications.

The Mist Fighter Collectors provides the ultimate in filtration technology and reduces mist collector maintenance. Years of filter life is expected depending on the contaminant and mist loading going through the filter. Time is money for the maintenance department, and the time this unit has to be looked at or touched is minimal.

## Key Features

- Airflows ranging from 500 CFM to 5500 CFM
- Motors are available from 1HP to 10HP for a wide variety of airflow requirements
- Direct drive backwards inclined non-overloading blowers
- Magnehelic Gauge for quick reference of filter loading
- Chevron style impinger prefilter reduces filter loading
- Heavy duty 11ga and 14ga construction
- Blower cabinet is internally baffled to provide quiet operation
- Deep panned inlet plenum with 1 1/4" drain for easy drainage

## Options

- Spray Nozzles for filter flushing of sticky, gelled contaminants
- Floor Stand
- Machine mount capability on smaller units
- HEPA Module after blower module

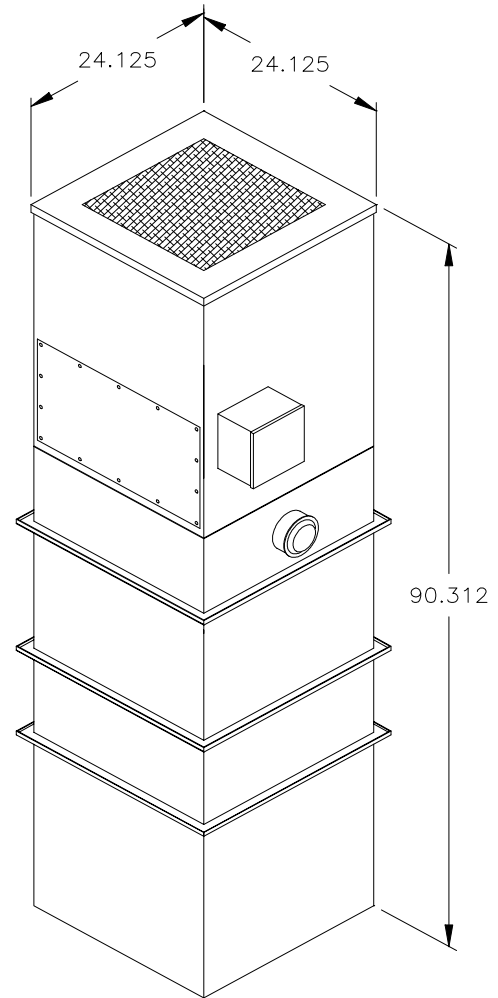

*MF-2000 series unit shown*

Unit Type	CFM	Mtr HP
MF-500	500	1.0
MF-1000	1000	1.5
MF-2015	1500	1.5
MF-2030	2000	3.0
MF-4050	3000	5.0
MF-4075	3500	7.5
MF-6075	4500	7.5
MF-6100	5500	10.0